



**Tel: 631-588-8820**  
**Fax: 631-588-8953**  
 2059 9th Avenue  
 Ronkonkoma, NY 11779

## CAST-IN ALUMINUM & BRONZE HEATERS

### **OMEGA ULTRACAST**

Omega Cast-In heaters combine top quality tubular heaters and high thermal conductivity non-ferrous alloys.

The heater elements are tested on a 100% basis before and after casting. Modern foundry techniques ensure a dense, porosity free casting.

After casting the heaters are machined to ensure a close contact on the working surface. Cast In heaters can be supplied with clamping straps or with built in clamping means. Omega can supply heaters with leads in armor, post terminals, terminal housing and a variety of electrical terminations. Standard cooling tube terminations are also available. Casting quality is maintained by periodic radiographic testing. Diagnostic radiography services are available if required.

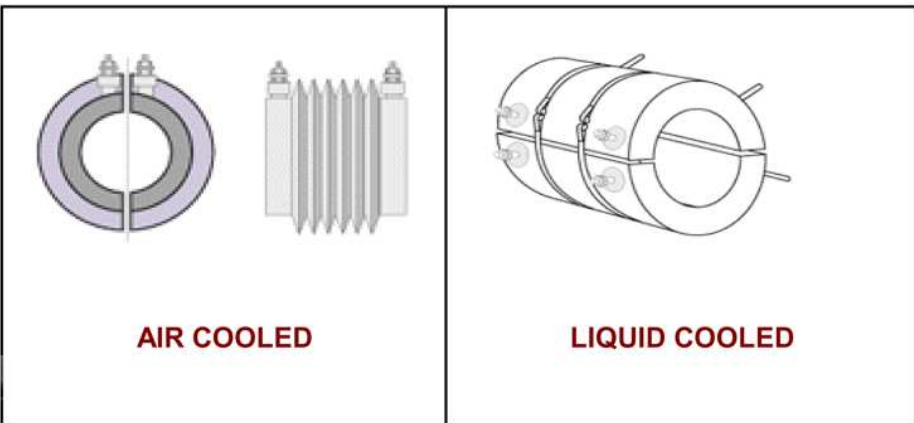
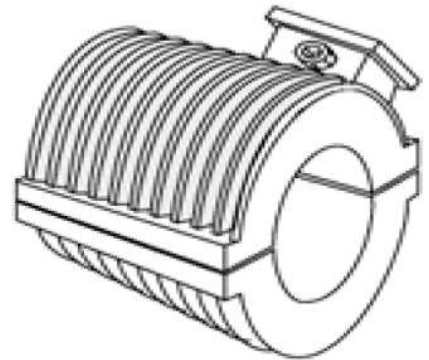

**SPECIFICATIONS:**  
**SIZE:** Any practical size and shape  
**WATTAGE:** Aluminum - up to 35 watts/sq. in.  
 Bronze - up to 50 watts/sq. in.  
**VOLTS:** 120, 240, 480 Standard Special voltage to order.  
**MAX. TEMP:** Aluminum - 700 deg. F (375 deg.C)  
 Bronze - 1000 deg F. (650 deg.C)  
**MACHINING TOLERANCE:**  
 .005" Standard.

*Normal 4 -6 week delivery No set-up or tooling charges*